

	SJ1	SJ3	SJ5	SJ7
21	Standard Conf.	Standard Conf.	Standard Conf.	Standard Conf.
23	Test Blade C conf.	Test Blade C conf.	Test Blade C conf.	Test Blade C conf.

	SJ2	SJ4	SJ6	SJ8
21	DC pick-up	DC pick-up	DC pick-up	DC pick-up
23	AC pick-up	AC pick-up	AC pick-up	AC pick-up

Notes:  
-C1,C2 ara balancing capacitor between blades fed in phase

RFtrapDrive

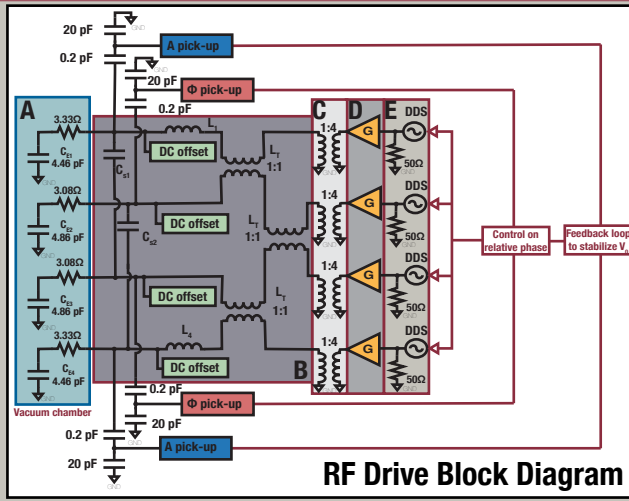

	SJ13	SJ14	SJ15	SJ16
21	Low impedance feeding on Blade D	Low impedance feeding on Blade C	Low impedance feeding on Blade A	Low impedance feeding on Blade B
23	50 Ohm impedance feeding on Blade D	50 Ohm impedance feeding on Blade C	50 Ohm impedance feeding on Blade A	50 Ohm impedance feeding on Blade B

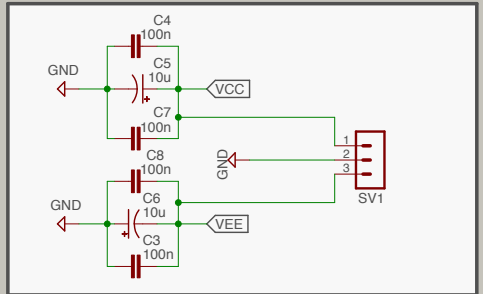
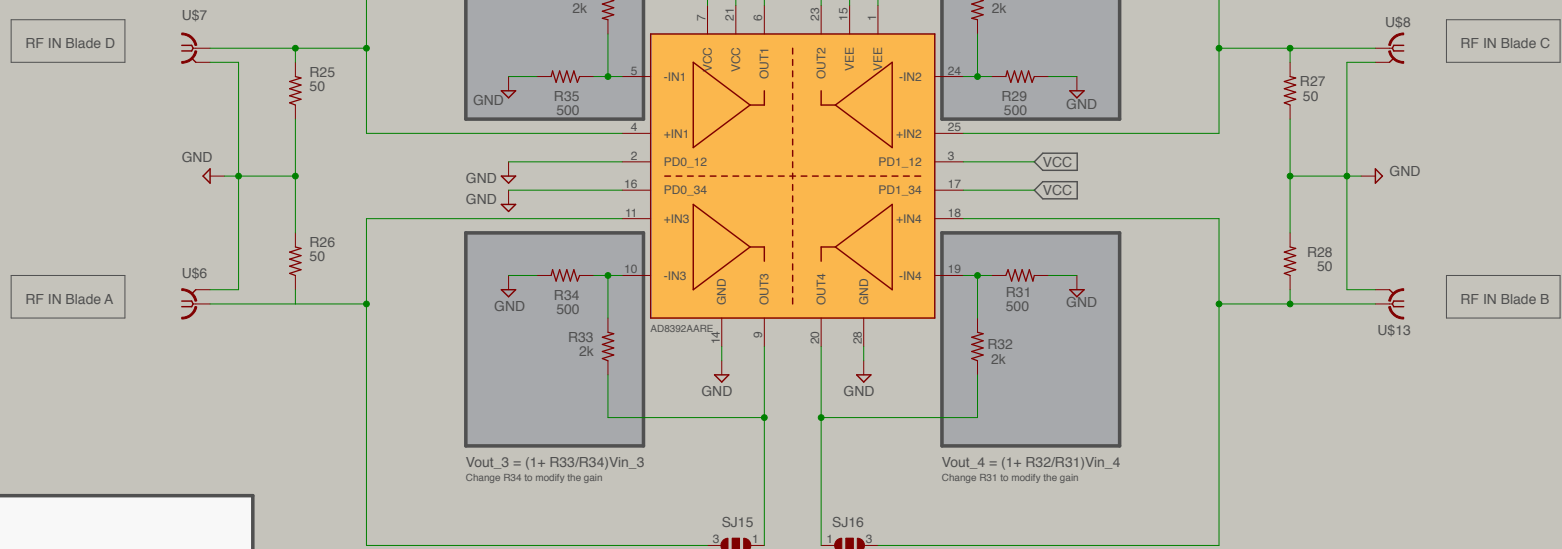

Notes:  
 PD0\_12 and PD1\_12 set the output impedance and the quiescent current for the first and the second channel. The same for PD0\_34 and PD1\_34.