

## BIASING OF HSWA2-30DR+ SPDT SWITCH WITH A 5V SUPPLY VOLTAGE

The HSWA2-30DR+ switch uses a patented CMOS technology and operates with single positive supply voltage from 2.7V to 3.3V. This model has a patent pending low noise negative voltage generator which produces internally the negative supply voltage required for CMOS logic.

For applications where the system voltage is +5V instead of +3V specified for CMOS switches, a resistive voltage divider should be used to reduce the voltage from +5V to +3V as shown below in *Figure 1*. For low noise applications it is preferable to use a low noise LDO (Low Drop-Out) voltage regulator such as MAX8878 (preset to 3V), as shown in *Figure 2*.

**Figure 1: HSWA2-30DR+ powered from a Voltage Divider**

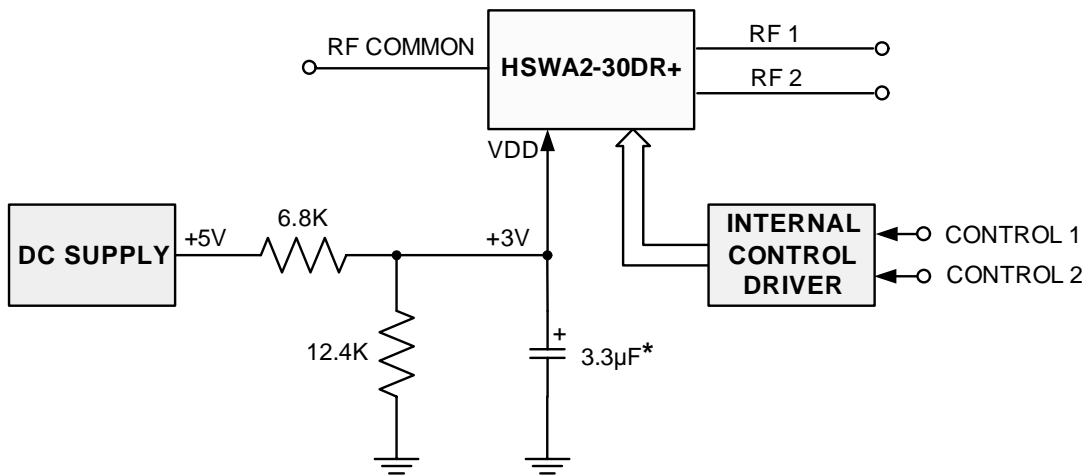

\*3.3μF capacitor should be placed close as possible to the Switch.

**Figure 2: HSWA2-30DR+ powered from a Low Drop-Out Voltage Regulator**

